

1. APPLICABLE MODELS & USAGE
適用機種及び用途

T015 Automatic chain-off thread cutter
自動糸切り装置

Applicable models
適用機種

All models of MO-1500G series
MO-1500Gシリーズ全機種

All models of MO-1500H series
MO-1500Hシリーズ全機種

Usage
用途

Automatic chain-off thread cutter
自動空環糸切り用

Ref. No.	Note 注記	Part No. 品番	Description	E. C. 変更年月	品名	Amt. Req. 数量
1		MAT-015001A0	AUTOMATIC CHAIN-OFF THREAD CUTTER		ｼﾞｯﾄﾞ-ｲﾄｷﾘｯﾁ 200V ｸﾐ	1
2		MAT-015002A0	AUTOMATIC CHAIN-OFF THREAD CUTTER		ｼﾞｯﾄﾞ-ｲﾄｷﾘｯﾁ 380V ｸﾐ	1
3		MAT-015003A0	AUTOMATIC CHAIN-OFF THREAD CUTTER		ｼﾞｯﾄﾞ-ｲﾄｷﾘｯﾁ 100V ｸﾐ	1
4		MAT-015004A0	AUTOMATIC CHAIN-OFF THREAD CUTTER		ｼﾞｯﾄﾞ-ｲﾄｷﾘｯﾁ 115V ｸﾐ	1
5		MAT-015005A0	AUTOMATIC CHAIN-OFF THREAD CUTTER		ｼﾞｯﾄﾞ-ｲﾄｷﾘｯﾁ 220V ｸﾐ	1
6		MAT-015006A0	AUTOMATIC CHAIN-OFF THREAD CUTTER		ｼﾞｯﾄﾞ-ｲﾄｷﾘｯﾁ 240V ｸﾐ	1
7		MAT-015007A0	AUTOMATIC CHAIN-OFF THREAD CUTTER		ｼﾞｯﾄﾞ-ｲﾄｷﾘｯﾁ 415V ｸﾐ	1
8		MAT-015008A0	AUTOMATIC CHAIN-OFF THREAD CUTTER		ｼﾞｯﾄﾞ-ｲﾄｷﾘｯﾁ 440V ｸﾐ	1

2. KNIFE & MAGNET COMPONENTS
 メス・マグネット関係

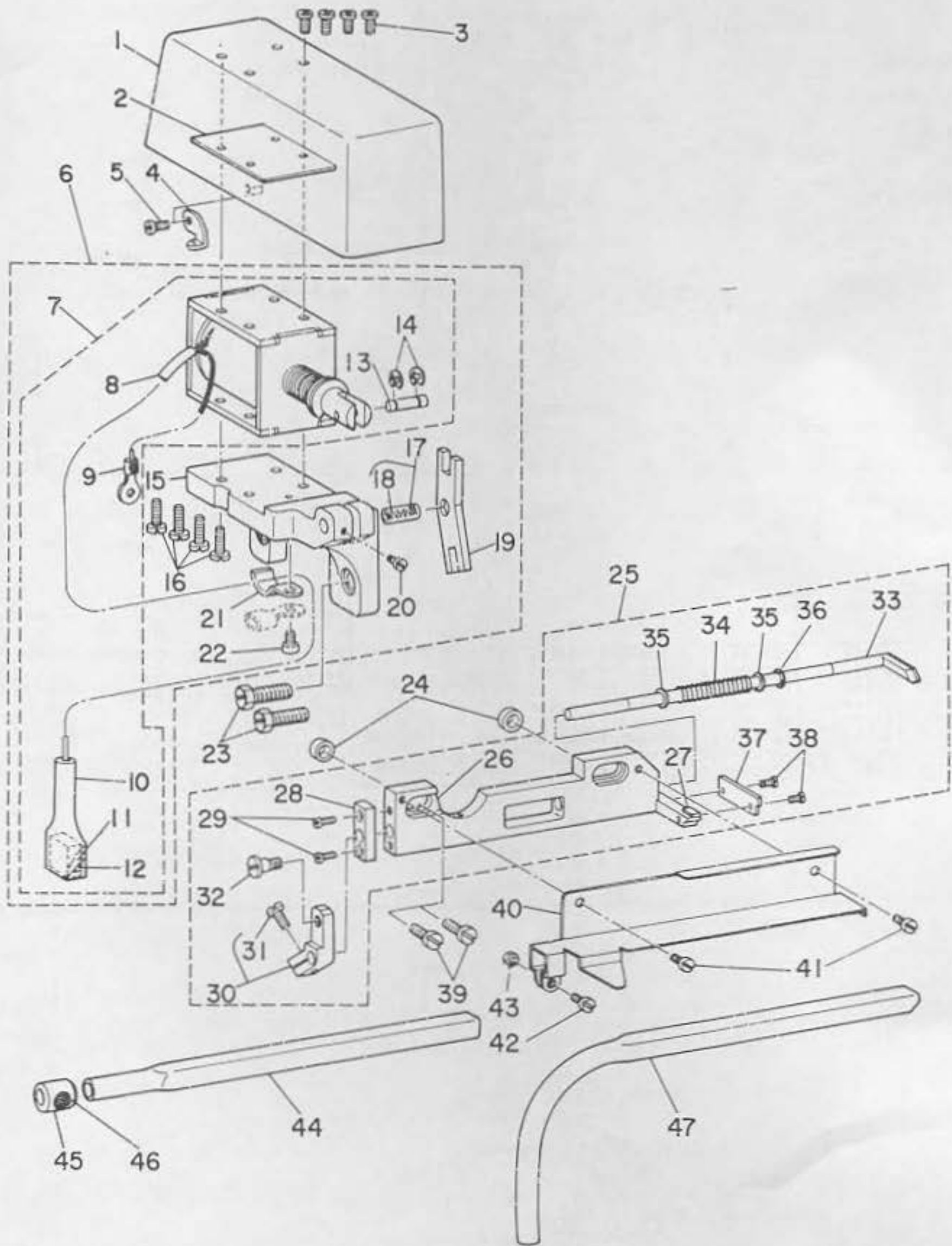

3. HEAD & THREAD TENSION RELEASE MAGNET COMPONENTS
 頭部・糸ゆるめマグネット関係

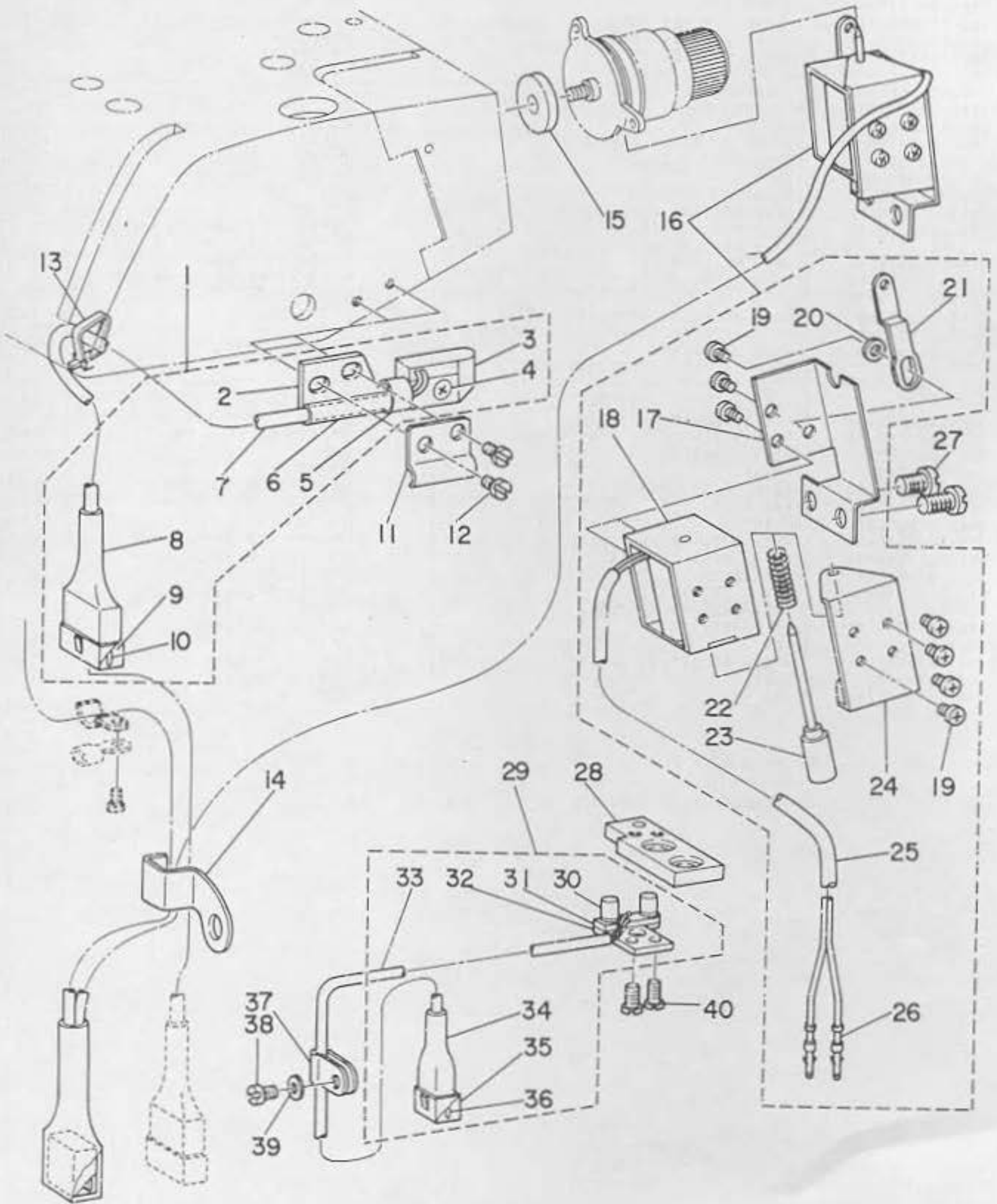

Ref. No.	Note	Part No. 品番	Description	E. C. 変更年月	品名	Amt Req 数量
1		MAT-015040A0	LIGHT RECEIVING ELEMENT ASM,		シ*コ-ソシ クミ	1
2		MAT-01504000	LIGHT RECEIVING ELEMENT BASE		シ*コ-ソシ トリツケタイ	(1)
3		MAT-01224000	LIGHT RECEIVING ELEMENT CASE		シ*コソシ ケ-ス	(1)
4		SM-2860601-SC	SCREW M16 L=10		マルササネシ*	(1)
5		MAT-01228000	TUBE		ヒシチユ-フ* (A)	(1)
6		MAT-01229000	TUBE		ヒシチユ-フ* (B)	(1)
7		HW-3000200-00	CORD		シ*コ- コ-ト*	(1,1)
8		MAT-81119T00	4-POLE PLUG COVER		4P フ*ラク*カハ*-	(1)
9		MAI-15042000	4-POLE PLUG, WHITE		4P ナイロンフ*ラク* シロ	(1)
10		D6043-555-800	PIN-SHAPE TERMINAL, MALE		ヒ*ン タ-ミナル オス	(3)
11		MAT-01506000	CORD PRESSER B		コ-ト*オサエ B	1
12		SS-3090510-SP	SCREW 9/64-40 L=5		マルサシ* 9/64-40 L= 5	2
13		GES-12153000	CLIP A		ソクセンハ*ント* A	1
14		MAT-81129T00	CORD COVER		コ-ト*カハ*-	1
15		WP-0612516-SD	WASHER 6.1X15.2X2.5		ヒラサ*カ*ネ 6.1X15.2X2.5	1
16		MAT-015050A0	THREAD TENSION RELEASE MAGNET ASM,		イトユルメマク*ネツト クミ	1
17		MAT-01505000	THREAD TENSION RELEASE MAGNET BASE		イトユルメマク*ネツト クミ	(1)
18		MAT-81122T00-A	TENSION RELEASE MAGNET		イトユルメマク*ネツト	(1)
19		SM-4030411-SB	SCREW M3X0.5 L=4		ナ*ネシ* M3X0.5 L= 4	(7)
20		WP-0330500-MB	SPRING WASHER M3		ヒラサ*カ*ネ コカ*タマ M3	(1)
21		115-45704	LOOPER THREAD TAKE-UP, LEFT		ル-ハ*チンヒ*ン ヒタ*リ	(1)
22		MAT-81124T00-A	SPRING		イトユルメマク*ネツトハ*ネ	(1)
23		MAT-81123T00-A	TENSION RELEASING PLUNGER		イトユルメマク*ラツシ*ヤ-	(1)
24		MAT-81125T00-A	TENSION RELEASING MAGNET COVER		イトユルメマク*ネツトカハ*-	(1)
25		HW-5L12S22-28	CABTYRE CORD		ランフ*コ-ト*	(1,2)
26		D6043-555-800	PIN-SHAPE TERMINAL, MALE		ヒ*ン タ-ミナル オス	(2)
27		SS-7120710-SP	SCREW 3/16-28 L=7		マルヒラサシ* 3/16-28 L= 7.0	2
28		MAT-01503000	THROAT PLATE BASE		ハリイタタイ	1
29		MAT-015070A0	LIGHT EMITTING DIODE ASM,		ハツコ-タ*イオ-ト* クミ	1
30		MAT-01510000	TUBE		ヒシチユ-フ*	(2)
31		MAT-01511000	LIGHT EMITTING DIODE BASE		ハツコ-タ*イオ-ト*タイ	(1)
32		MAT-01507000	PRINTED CIRCUIT BOARD		ハツコ-タ*イオ-ト*キハ*ン	(1)
33		HW-5L12S22-28	CABTYRE CORD		ランフ*コ-ト*	(0,1)
34		MAT-81126T00	2-POLE PLUG COVER		2P フ*ラク*カハ*-	(1)
35		MAI-15040000	2-POLE PLUG		2キヨク ナイロン フ*ラク*	(1)
36		D6043-555-800	PIN-SHAPE TERMINAL, MALE		ヒ*ン タ-ミナル オス	(2)
37		G5066-110-000	CORD HOLDER		3マ*ヨ- ケ-フ*オサエ	1
38		SS-6090910-SP	SCREW 9/64-40 L=9		ヒラサシ* 9/64-40 L= 9	1
39		WP-0370316-SD	WASHER 3.7X8X0.3		ヒラサ*カ*ネ 3.7X8X0.3	1
40		SS-7080510-SP	SCREW 1/8-44 L= 4.5		マルヒラサシ* 1/8-44 L= 4.5	2

CONTROL BOX COMPONENTS
コントロール ボックス関係

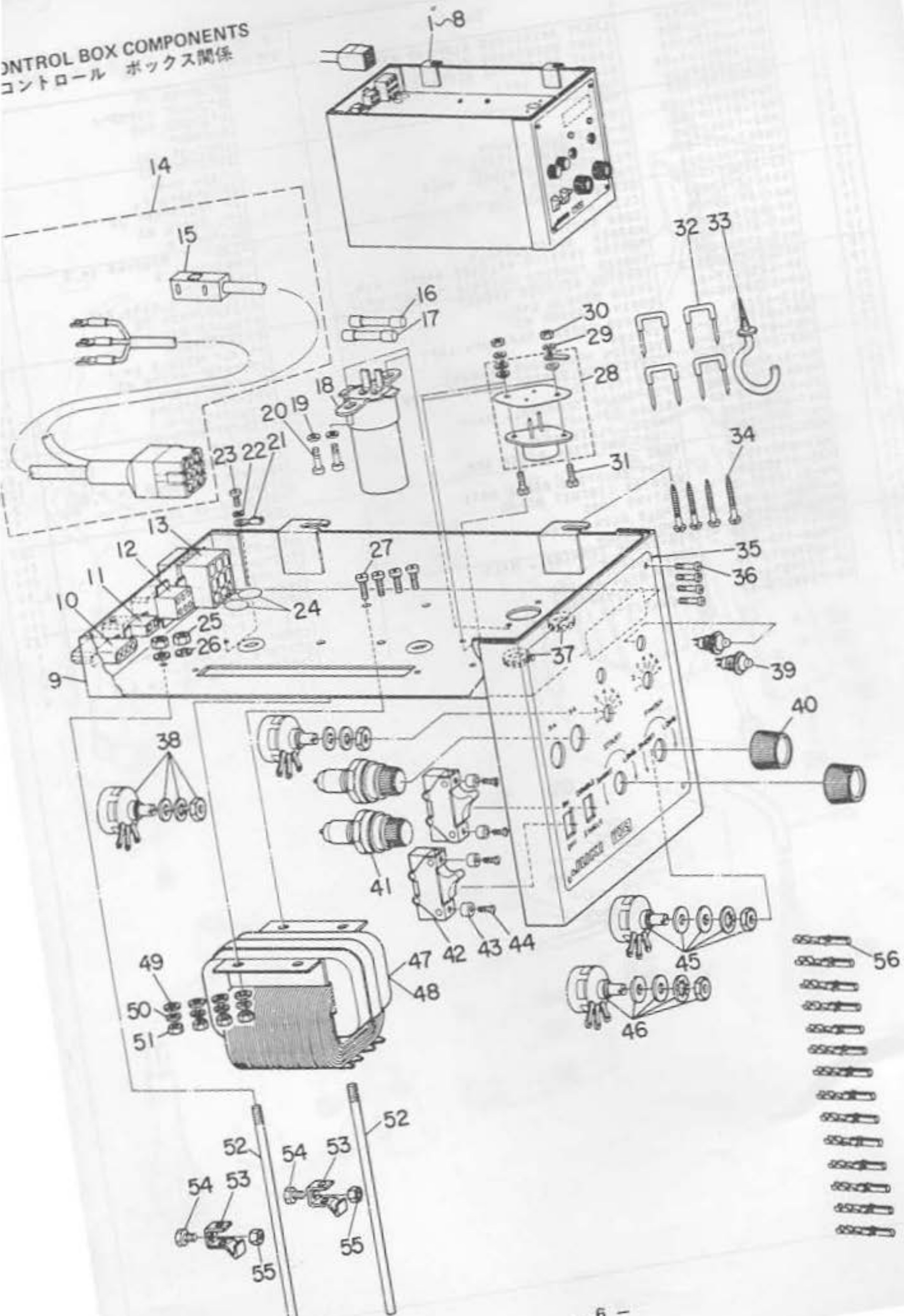

Ref. No.	Note	Part No. 品番	Description	E. C. 変更年月	品名	Am Rec 数
1		MAT-015120A0	CONTROL BOX ASM, (200V)		コントロールボックス 200V クミ	1
2		MAT-015121A0	CONTROL BOX ASM, (380V)		コントロールボックス 380V クミ	1
3		MAT-015122A0	CONTROL BOX ASM, (100V)		コントロールボックス 100V クミ	1
4		MAT-015123A0	CONTROL BOX ASM, (115V)		コントロールボックス 115V クミ	1
5		MAT-015124A0	CONTROL BOX ASM, (220V)		コントロールボックス 220V クミ	1
6		MAT-015125A0	CONTROL BOX ASM, (240V)		コントロールボックス 240V クミ	1
7		MAT-015126A0	CONTROL BOX ASM, (415V)		コントロールボックス 415V クミ	1
8		MAT-015127A0	CONTROL BOX ASM, (440V)		コントロールボックス 440V クミ	1
9		MAT-01241000-B	CONTROL BOX		コントロールボックス	1
10		HAI-15043000	4-POLE RECEPTACLE, WHITE		4P リセフ*タケル	1
11		HAI-15041000	2-POLE RECEPTACLE		2P リセフ*タケル	1
12		D6029-555-80B	6-POLE RECEPTACLE, WHITE		6P アイロンリセフ*タケル	1
13		MAT-01278000	9-POLE RECEPTACLE, WHITE		9P アイロンリセフ*タケル	1
14		MAT-012601A0-B	POWER SOURCE CORD ASM,		テングアンコート* クミ	1
15		MAT-012650A0	SAFETY SWITCH ASM,		アセ*ン スイッチ クミ	(1
16		D6110-555-800	FUSE 5A		ヒューズ* 5A	2
17		MAT-80143T00	FUSE 3A		ヒューズ* 3A	2
18		HC-0003500-00	CAPACITOR		コンデンサ 220MF 160V タンカイ	1
19		WS-0310702-KB	SPRING WASHER 3,1X5,3X0,7		ハ*ネワ*カ*ネ 3,1X5,3X0,7	2
20		SH-4030501-SB	SCREW M3X0,5 L*5		ナ*ネジ* M3X0,5 L= 5,0	2
21		HP-1A43PGC-12	GROUND WIRE TERMINAL		アツチヤクタンシ	1
22		WS-0310702-KB	SPRING WASHER 3,1X5,3X0,7		ハ*ネワ*カ*ネ 3,1X5,3X0,7	1
23		SH-4030801-SB	SCREW M3X0,5 L*8		ナ*ネジ* M3X0,5 L= 8,0	1
24		HC-0061010-T0	CAPACITOR		コンデンサ 0,01MF 1KV シ*	2
25		NH-6040000-SB	NUT M4X0,7		6カクナツ M4X0,7 152	2
26		WP-0450501-SB	WASHER		ヒラサ*カ*ネ	2
27		SH-4041201-SB	SCREW M4X0,7 L*12		ナ*ネジ*	4
28		HT-4214110-01	POWER TRANSISTOR		トランジスタ	1
29		WS-0310702-KB	SPRING WASHER 3,1X5,3X0,7		ハ*ネワ*カ*ネ 3,1X5,3X0,7	2
30		NH-6030000-SB	NUT M3X0,5		6カクナツ M3X0,5 152	2
31		SH-4031201-SB	SCREW M3X0,5 L*12		ナ*ネジ* M3X0,5 L=12	2
32		MAO-11532000	STAPLE		コート* スタツプ*ル	4
33		MAT-81163T00	CORD HOLDER		コート* カケ	1
34		SK-3452500-SC	WOOD SCREW D=4,5 L=25		ツルネジ* D=4,5 L=25	4
35		MAT-01243000-A	CONTROL BOX SUPPORT PLATE		コントロール* シ*ハ*ン	1
36		SH-4920501-SB	SCREW M2,6X0,45 L*5		ナ*ネジ* M2,6X0,45 L= 5	4
37		MAT-01263000	RUBBER BUSHING		ゴム* フ*ツ*シ	4
38		MAT-01247000	VARIABLE RESISTOR		カ*ン*チ*イ*ク*ワ*	2
39		MAT-01264000	LIGHT EMITTING DIODE		ヒョ*シ* ヨ* ハツコ*タ*イ*オ*ト*	2
40		MAT-01251000	VOLUME KNOB		ホ*リユ*ム ツマミ	2
41		MAT-80142T00	FUSE HOLDER		ヒューズ* ホルダ*ー	2
42		MAT-01252000	TUMBLER SWITCH		タンブラ*ス*イ*ツ*チ	2
43		MAT-01250000	TUMBLER SWITCH COVER		タンブラ*ス*イ*ツ*チ カ*ハ*ー	4
44		SH-1921001-SB	SCREW M1,2 L*10		ツラコネジ* M1,2 L=10	4
45		MAT-01249000	VARIABLE RESISTOR		カ*ン*チ*イ*ク*ワ*	1
46		MAT-01248000	VARIABLE RESISTOR		カ*ン*チ*イ*ク*ワ*	1
47	004	MAT-01246000	TRANSFORMER A		チ*ン*タ*ン*ト*ラ*ン*ス (A)	1
48	005	MAT-01246100	TRANSFORMER B		チ*ン*タ*ン*ト*ラ*ン*ス (B)	1
49		WP-0450501-SB	WASHER		ヒラサ*カ*ネ	4
50		WS-0411002-KB	SPRING WASHER 4		ハ*ネワ*カ*ネ	4
51		NH-6040000-SB	NUT M4X0,7		6カクナツ M4X0,7 152	4
52		MAT-01254000	SUPPORTING STUD		*ハ*ン*オ*ワ*エ シ*チ*ク	2
53		MAT-01255000	SET PLATE		*ハ*ン*ト*メ*カ*ク*	2
54		SH-9040603-SC	SCREW M4X0,7 L*6		6カクネ*ネジ M4X0,7 L= 6	2
55		NH-6040000-SB	NUT M4X0,7		6カクナツ M4X0,7 152	2
56		D6042-555-800	PIN-SHAPE TERMINAL, FEMALE		ピ*ン タ*ミ*ナル メ*ス	14

Note (注記) 004 For 100V, 115V, 200V, 240V.

005 For 220V, 380V, 415V, 440V.

*Control box asm. includes No. 9-56 of page 7 and No. 1-46 of page 9.

100 V, 115 V, 200 V, 240 V 用

220 V, 380 V, 415 V, 440 V 用

コントロールボックス(組)は、7頁の9-56番及び9頁の1-46までが含まれる。

5. PRINTED CIRCUIT BOARD COMPONENTS
基板関係

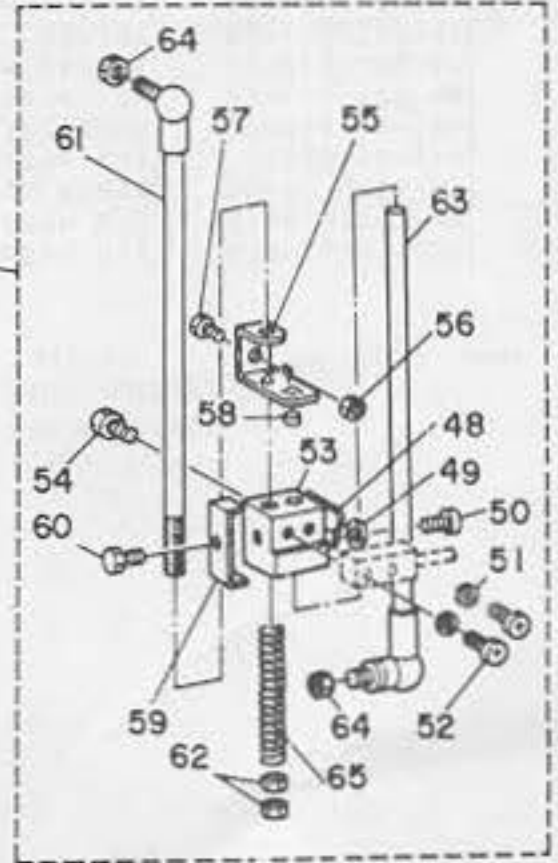
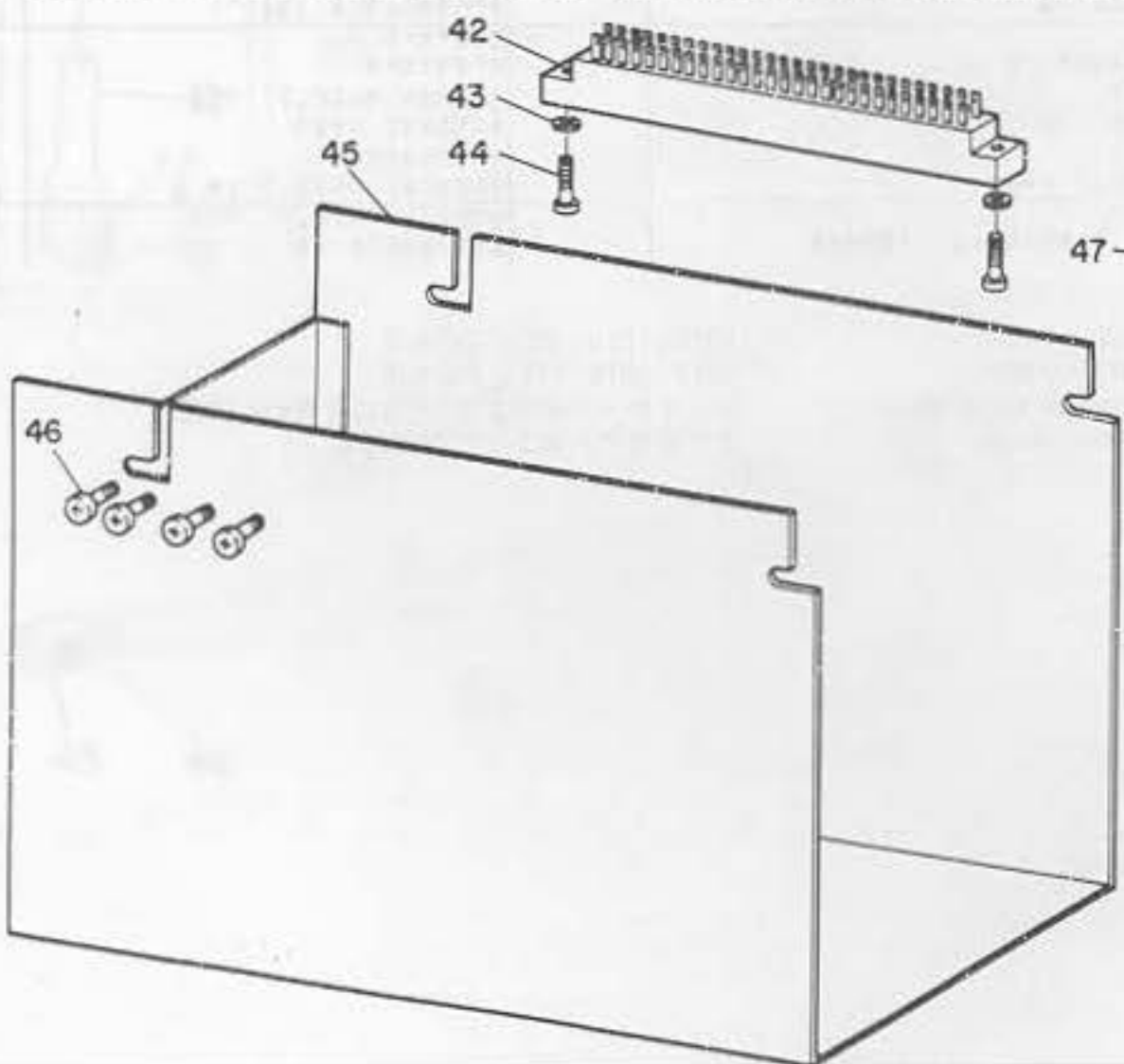
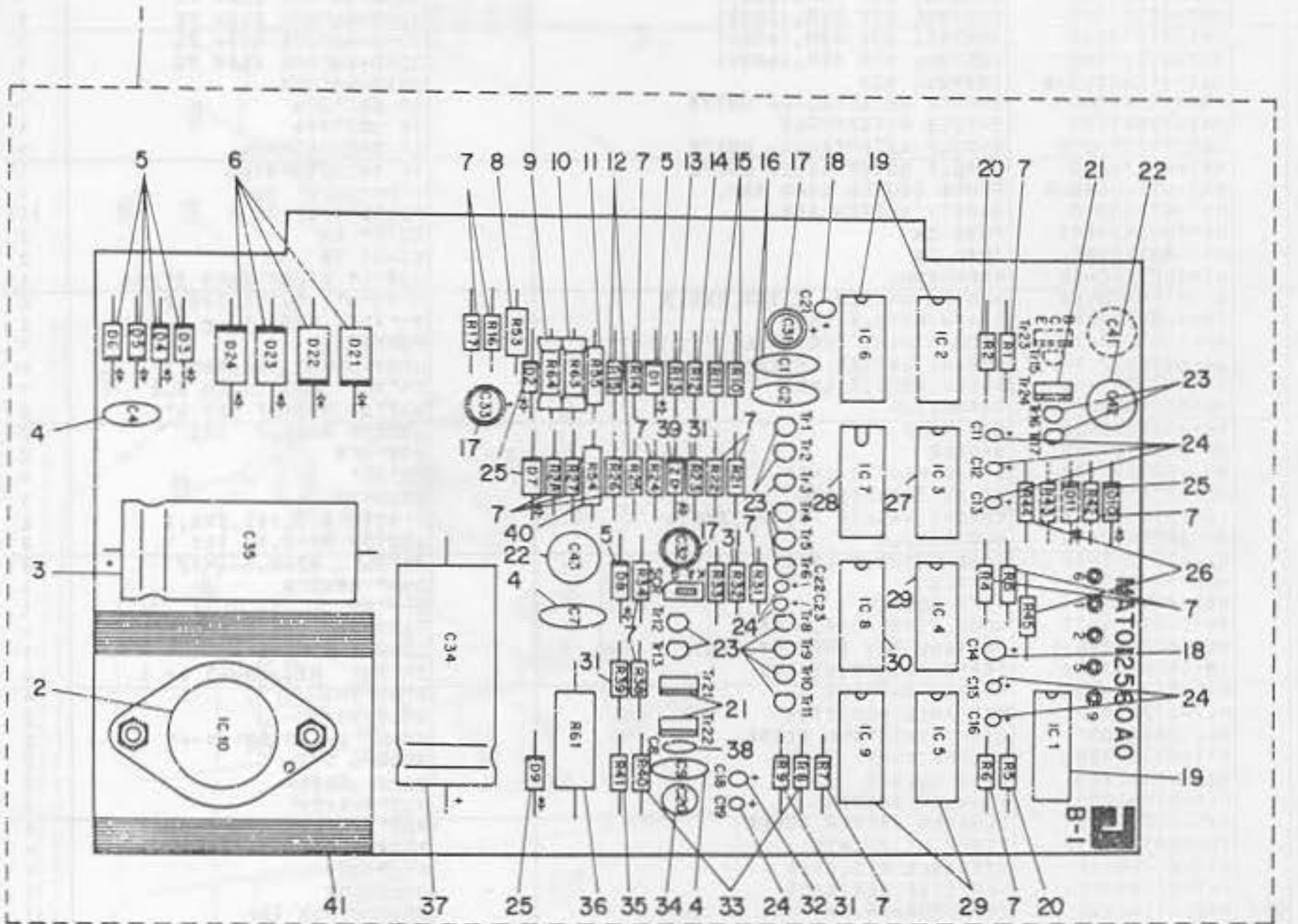

Ref No.	Note	Part No. 品番	Description	E. C. 変更年月	品名	Amf Req 数量
1		HAT-012560A0	PRINTED CIRCUIT BOARD ASM.		プリント基板	1
2		HL-0016100-00	IC TA78005H		IC (TA78005H)	(1)
3		HCA-350H1024	CAPACITOR 1000MF 35V		コンデンサ 1000MF 35V	(1)
4		HC-0003900-00	CAPACITOR 0.1MF 50V		コンデンサ 0.1MF 50V	(3)
5		HG-0002700-00	DIODE SR1FH-2		ダイオード (SR1FH-2)	(6)
6		HG-0002600-00	DIODE SR3AH-4		ダイオード (SR3AH-4)	(4)
7		HR-0001010-20	RESISTOR 1 KILO OHM 1/4W		抵抗器 1K 1/4W	(19)
8		HR-0002050-P0	SOLID RESISTOR 5 OHM 1/2W		抵抗器 5Ω 1/2W	(1)
9		HR-0007027-00	RESISTOR 27 OHM 1W		抵抗器 27Ω 1W	(1)
10		HR-0007010-10	RESISTOR 100 OHM 1W		抵抗器 100Ω 1W	(1)
11		HR-0002051-30	SOLID RESISTOR 51 KILO OHM 1/2W		抵抗器 51K 1/2W	(1)
12		HR-0001020-30	RESISTOR 20 KILO OHM 1/4W		抵抗器 20K 1/4W	(2)
13		HR-0001010-30	RESISTOR 10 KILO OHM 1/4W		抵抗器 10K 1/4W	(3)
14		HR-0001047-10	SOLID RESISTOR 470 OHM 1/4W		抵抗器 470Ω 1/4W	(1)
15		HR-0001047-40	RESISTOR 470 OHM 1/4W		抵抗器 470Ω 1/4W	(2)
16		HC-0004100-00	CAPACITOR 0.047MF 50V		コンデンサ 0.047MF 50V	(2)
17		HCA-160J4704	CAPACITOR 47MF 16V		コンデンサ 47MF 16V	(3)
18		HC-0002900-00	CAPACITOR 10MF 16V		コンデンサ 10MF 16V	(2)
19		HL-0001700-00	INTEGRATED CIRCUIT		IC (SN74121N)	(5)
20		HR-0001039-30	RESISTOR 39 KILO OHM 1/4W		抵抗器 39K 1/4W	(2)
21		HT-0002600-00	TRANSISTOR 2SD358-D		トランジスタ (2SD358-D)	(1)
22		HC-0003100-00	CAPACITOR 0.1MF 150V		コンデンサ 0.1MF 150V	(2)
23		HT-0002400-00	TRANSISTOR 2SC711-E		トランジスタ (2SC711-E)	(14)
24		HC-0003700-00	CAPACITOR 4.7MF 16V		コンデンサ 4.7MF 16V	(8)
25		HG-0002800-00	DIODE SR1FH-8		ダイオード (SR1FH-8)	(4)
26		HR-0001068-20	RESISTOR 6.8 KILO OHM 1/4W		抵抗器 6.8K 1/4W	(2)
27		HL-0000400-00	IC SN7404N		IC (SN7404N)	(1)
28		HL-0001400-00	IC SN7474N		IC (SN7474N)	(1)
29		E9612-501-000	IC DM946N		IC (SN15846N)	(1)
30		HL-0006300-00	IC HD2207P		IC (MC862)	(1)
31		HR-0001020-20	RESISTOR 2 KILO OHM 1/4W		抵抗器 2K 1/4W	(4)
32		HC-0003600-00	CAPACITOR 4.7MF 16V		コンデンサ 4.7MF 16V	(1)
33		HR-0001015-30	RESISTOR 15 KILO OHM 1/4W		抵抗器 15K 1/4W	(2)
34		HC-0005500-00	CAPACITOR 22MF 16V		コンデンサ 22MF 16V	(1)
35		HR-0001030-30	RESISTOR 30 KILO OHM 1/4W		抵抗器 30K 1/4W	(1)
36		HR-0032040-00	RESISTOR 40 OHM 3W		抵抗器 40Ω 3W	(1)
37		HC-0005600-00	CAPACITOR 100MF 160V		コンデンサ 100MF 160V	(1)
38		HCL-500B10T1	CAPACITOR		コンデンサ 0.01MF 50V	(1)
39		HG-0002900-00	DIODE		ダイオード (HZ203-1)	(1)
40		HR-0002051-00	RESISTOR 51 OHM 1/2W		抵抗器 51Ω 1/2W	(1)
41		HAT-01257000	LOW VOLTAGE IC FIN		低電圧ICフィン	(1)
42		HAT-01253000	PRINTED BOARD CONNECTOR		基板コネクタ	1
43		WS-0310702-KS	SPRING WASHER 3.1X5.9X0.7		バネワッシャー 3.1X5.9X0.7	2
44		SH-4030801-SB	SCREW M3X0.5 L=8		ネジ M3X0.5 L=8.0	2
45		HAT-01242000	CONTROL BOX COVER		制御箱カバー	1
46		SH-4040601-SB	SCREW M4X0.7 L=6		ネジ M4X0.7 L=6	4
47		HAT-012660A0	CONNECTING ROD ASM.		連結棒	1
48		B3538-112-000	OIL WICK HOLDER		オイル Wickホルダ	(1)
49		WP-0330501-SB	WASHER M3		ワッシャー M3	(1)
50		SH-4030411-SB	SCREW M3X0.5 L=4		ネジ M3X0.5 L=4	(1)
51		WP-0330500-MB	SPRING WASHER M3		バネワッシャー M3	(2)
52		SH-4031201-SB	SCREW M3X0.5 L=12		ネジ M3X0.5 L=12	(2)
53		HAT-81133T00	SAFETY SWITCH INSTALLING BASE		安全スイッチ取り付け台	(1)
54		SH-9060813-SE	SCREW M6 L=8		六角ネジ M6 L=8	(1)
55		HAT-81134T00	MAGNET MOUNTING BASE		マグネット取り付け台	(1)
56		NH-6080721-SE	NUT M8		六角ナット M8	(1)
57		SH-9081423-SE	SCREW M8 L=14		六角ネジ M8 L=14	(1)
58		HAT-01266000	MAGNET		マグネット	(1)
59		HAT-81136T00	STOPPER		止り止め	(1)
60		SH-9060813-SE	SCREW M6 L=8		六角ネジ M6 L=8	(1)
61		HAT-81137TA0	JOINT BAR ASM. B		連結棒 B	(1)
62		NH-6060003-SC	NUT M6		六角ナット M6	(2)
63		D7117-555-BA0	JOINT ASM.		連結棒	(1)
64		NH-6060001-SE	SCREW M6		六角ネジ M6	(2)
65		D7130-555-80A	SPRING		バネ	(1)

NUMERICAL INDEX OF PARTS

索引

Part No. 品番	Page 頁	Ref. No.	Part No. 品番	Page 頁	Ref. No.	Part No. 品番	Page 頁	Ref. No.	Part No. 品番	Page 頁	Ref. No.
EXCLUSIVE PARTS 115-45704	専用部品 5	21	EXCLUSIVE PARTS "M" 専用部品 "M"			HAT-81100700	3	46	WS-0411002-KB	7	50
EXCLUSIVE PARTS "B"	専用部品 "B"		HAI-15040000	5	35	HAT-81119700	5	8			
B1504-761-000	3	24	HAI-15041000	7	11	HAT-81122700-A	5	18			
B2116-019-0A0	3	17	HAI-15042000	5	9	HAT-81123700-A	5	23			
B2526-704-000	3	4	HAI-15043000	7	10	HAT-81124700-A	5	22			
B3538-112-000	4	48	KAC-11532000	7	32	HAT-81125700-A	5	24			
OIL WICK	油心		HAT-005010A0	3	6	HAT-81126700	5	34			
CO-2020000-00	3	18	HAT-00501000	3	15	HAT-81129700	5	14			
EXCLUSIVE PARTS "D"	専用部品 "D"		HAT-005020A0	3	30	HAT-81131700	3	10			
D2611-555-80B	3	21	HAT-00504000	3	33	HAT-81132700	3	2			
D6029-555-80A	3	11	HAT-00505000	3	37	HAT-81133700	9	53			
D6029-555-80B	7	12	HAT-00509000	3	19	HAT-81134700	9	55			
D6042-555-800	7	56	HAT-01224000	5	3	HAT-81136700	9	59			
D6043-555-800	3	12	HAT-01228000	5	5	HAT-811377A0	9	61			
D6043-555-800	5	10	HAT-01229000	5	6	HAT-81163700	7	33			
D6043-555-800	5	26	HAT-01241000-B	7	9	NUT	ナット				
D6043-555-800	5	36	HAT-01242000	9	45	NM-6030000-SB	7	30			
D6110-555-800	7	16	HAT-01243000-A	7	35	NM-6040000-SB	7	25			
D7117-555-8A0	9	63	HAT-01246000	7	47	NM-6040000-SB	7	51			
D7130-555-80A	9	65	HAT-01246100	7	48	NM-6040000-SB	7	55			
EXCLUSIVE PARTS "G"	専用部品 "G"		HAT-01247000	7	38	NM-6060001-SE	9	64			
GES-12153000	5	13	HAT-01248000	7	46	NM-6060003-SC	9	62			
G5066-110-000	5	37	HAT-01249000	7	45	NM-6080721-SE	9	56			
ELECTRON PARTS	電子部品		HAT-01250000	7	43	NS-6090310-SP	3	43			
E9612-501-000	9	29	HAT-01251000	7	40	SNAP RING	止メ輪				
HCA-160J4704	9	17	HAT-01252000	7	42	RE-0300000-K0	3	14			
HCA-350H1024	9	3	HAT-01253000	9	42	HINGE SCREW	段ネジ				
HCL-500B1071	9	38	HAT-01254000	7	52	SD-0500481-TP	3	32			
HC-0002900-00	9	18	HAT-01255000	7	53	SCREW	ネジ				
HC-0003100-00	9	22	HAT-012560A0	9	1	SK-3452500-SC	7	34			
HC-0003500-00	7	18	HAT-01257000	9	41	SM-1921001-SB	7	44			
HC-0003600-00	9	32	HAT-012601A0-B	7	14	SM-2860601-SC	5	4			
HC-0003700-00	9	24	HAT-01263000	7	37	SM-4030411-SB	5	19			
HC-0003900-00	9	4	HAT-01264000	7	39	SM-4030411-SB	9	50			
HC-0004100-00	9	16	HAT-012650A0	7	15	SM-4030501-SB	7	20			
HC-0005500-00	9	34	HAT-012660A0	9	47	SM-4030801-SB	7	23			
HC-0005600-00	9	37	HAT-01266000	9	58	SM-4030801-SB	9	44			
HC-0061010-70	7	24	HAT-01278000	7	13	SM-4031201-SB	7	31			
HG-0002600-00	9	6	HAT-015001A0	1	1	SM-4031201-SB	9	52			
HG-0002700-00	9	5	HAT-015003A0	1	3	SM-4040601-SB	3	3			
HG-0002800-00	9	25	HAT-015004A0	1	4	SM-4040601-SB	9	46			
HG-0002900-00	9	39	HAT-015005A0	1	5	SM-4041001-SB	3	16			
HL-0000400-00	9	27	HAT-015006A0	1	6	SM-4041201-SB	7	27			
HL-0001400-00	9	28	HAT-015007A0	1	7	SM-4920501-SB	7	36			
HL-0001700-00	9	19	HAT-015008A0	1	8	SM-9040603-SC	7	54			
HL-0006300-00	9	30	HAT-015002A0	1	2	SM-9060813-SE	9	54			
HL-0016100-00	9	2	HAT-015010A0	3	25	SM-9060813-SE	9	60			
HP-1A43PGC-12	3	9	HAT-01501000	3	26	SM-9081423-SE	9	57			
HP-1A43PGC-12	7	21	HAT-01502000	3	40	SS-3060410-SP	3	38			
HR-0001010-20	9	7	HAT-01503000	5	28	SS-3090510-SP	5	12			
HR-0001010-30	9	13	HAT-015040A0	5	1	SS-4080610-SP	3	29			
HR-0001015-30	9	33	HAT-01504000	5	2	SS-4090610-SP	3	20			
HR-0001020-20	9	31	HAT-015050A0	5	16	SS-5090610-SP	3	41			
HR-0001020-30	9	12	HAT-01505000	5	17	SS-6090630-SP	3	5			
HR-0001030-30	9	35	HAT-01506000	5	11	SS-6090810-SP	3	31			
HR-0001039-30	9	20	HAT-015070A0	5	29	SS-6090810-SP	3	42			
HR-0001047-10	9	14	HAT-01507000	5	32	SS-6090910-SP	5	38			
HR-0001047-40	9	15	HAT-01510000	5	30	SS-7080510-SP	5	40			
HR-0001068-20	9	26	HAT-01511000	5	31	SS-7090850-SP	3	22			
HR-0002050-P0	9	8	HAT-015120A0	7	1	SS-7120710-SP	5	27			
HR-0002051-00	9	40	HAT-015121A0	7	2	SS-7121410-SP	3	39			
HR-0002051-30	9	11	HAT-015122A0	7	3	SS-9151630-CP	3	23			
HR-0007010-10	9	10	HAT-015123A0	7	4	WASHER	座金				
HR-0007027-00	9	9	HAT-015124A0	7	5	WP-0330500-HB	5	20			
HR-0032040-00	9	36	HAT-015125A0	7	6	WP-0330500-HB	9	51			
HT-0002400-00	9	23	HAT-015126A0	7	7	WP-0330501-SB	9	49			
HT-0002600-00	9	21	HAT-015127A0	7	8	WP-0370316-SD	5	39			
HT-4214110-01	7	28	HAT-80102700	3	28	WP-0450501-SB	7	26			
HV-3000200-00	5	7	HAT-80105700	3	34	WP-0450501-SB	7	49			
HV-5F18516-AB	3	8	HAT-80106700	3	36	WP-0510516-SD	3	35			
HV-5L12522-2B	5	25	HAT-801117A0	3	7	WP-0612516-SD	5	15			
HV-5L12522-2B	5	33	HAT-80114700	3	13	WS-0310702-KB	7	19			
			HAT-80119700	3	1	WS-0310702-KB	7	22			
			HAT-80142700	7	41	WS-0310702-KB	7	29			
			HAT-80143700	7	17	WS-0310702-KS	9	43			
			HAT-81102700-A	3	27						
			HAT-8110470B	3	47						
			HAT-81104700	3	44						
			HAT-81105700	3	45						